



FOP 60 and OPTV Fibre-Optic Amplifier and Receiver

Features

- Interference-free pulse detection
- No electrical connection to OPTV receiver
- Blue-anodised aluminum housing
- Light weight and handy design





The FOP is a fibre-optic amplifier for KEM gear flow meters used in high-voltage applications. Its integral pickup detects the r.p.m. of the gears and the FOP provides a flow-proportional light pulse signal. The OPTV receiver will convert the light pulses into a current or voltage squarewave signal which may be used for evaluation.

Technical Data

FOP fibre-optic amplifier

power supply:	lithium battery
battery lifetime:	max. 2 years with 24h-operation
ambient temperature:	-20 up to +50°C
frequency range:	3 up to 1,000Hz
weight:	approx. 190 g
Ex-protection, IS:	 II 2 G EEx ia IIC T4/T5/T6, BVS 03 ATEX E 156
housing:	IP65, anodised aluminium (for dimensions please see drawings)

Marking

 Küppers Elektromechanik GmbH
 0123  II 2 G EEx ia IIC T4/T5/T6
 DMT 03 ATEX E 156

FOP60/**-**-** Ser.Nr. 123456789
 $-20^{\circ}\text{C} \leq T_a \leq 20^{\circ}\text{C}$ T6
 $\leq 40^{\circ}\text{C}$ T5
 $\leq 70^{\circ}\text{C}$ T4

The test sticker indicates year of building and person in charge of test.

Fibre-optic cable, silicone-free, ready-to-wire

type:	OKE1000-C, orange-coloured
cable diameter:	5.5mm
plug diameter:	< 8.5mm
bending radius:	> 10/50mm
tensile strength:	250/100N
bending strength in alternate directions:	> 10,000
ambient temperature:	-30 up to +80°C
plug type:	2 off LWST1000 65
protection class:	IP 65
cable length:	max. 10m
wire tip material:	nickel-silver (ARCAP)

Dimensional drawing FOP 60 (mm)

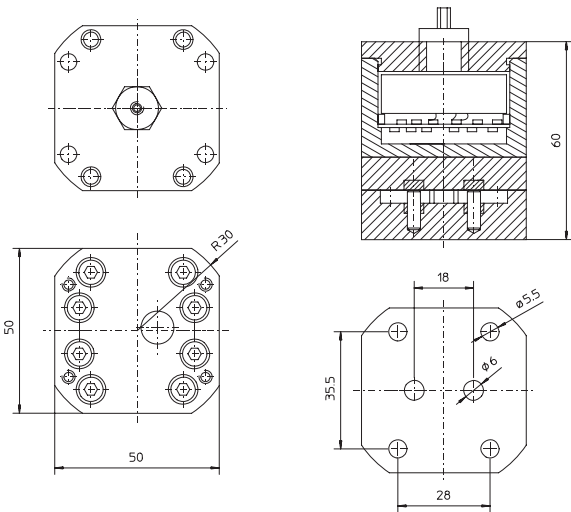

OPTV-02/X light pulse receiver and converter

ambient temperature:	-20 up to +60°C
supply voltage:	UB: +7 up to +30V
quiescent current:	IR < 1.1mA
output:	frequency output, constant pulsetime 500 µsec
electrical data, alternatively:	<i>voltage outputs (3-wire connection)</i>
	a) active output
	high level: $U_{high} > U_B - 0.6V - 2.5k\Omega \times I_{out} \text{ (mA)}$
	low level: $U_{low} < 0.6V + 1.3k\Omega \times I_{out} \text{ (mA)}$
	b) passive output
	high level: $U_{high} > U - I_{out} \text{ (mA)} \times 1.3k\Omega$
	low level: $U_{low} < 0.6V + 1.3k\Omega \times I_{out} \text{ (mA)}$
	U is the voltage applied at the output, max. 30V
	<i>current output (2-wire connection)</i>
	a) for UB < 9V (NAMUR supply units)
	high level: $I_{high} > 2.2\text{mA}$
	low level: $I_{low} < 1.1\text{mA}$
	b) for UB 7 up to 30V
	high level: $I_{high} = (U_B - 0.6V)/1.3k\Omega + I_{Low}$
	low level: $I_{low} = (U_B - 4V)/7.5k\Omega$
frequency range:	3 up to 2,000Hz according to flow meter
electrical connection:	two off 4-pin screw terminals for supply and output signals (cf. wiring schemes, page 5)
Ex protection:	 II 2 G EEx ia IIC T6, DMT 03 ATEX E 089X
housing:	grey-coloured polycarbonate for DIN hat top rail mounting

Dimensional drawing OPTV (mm)

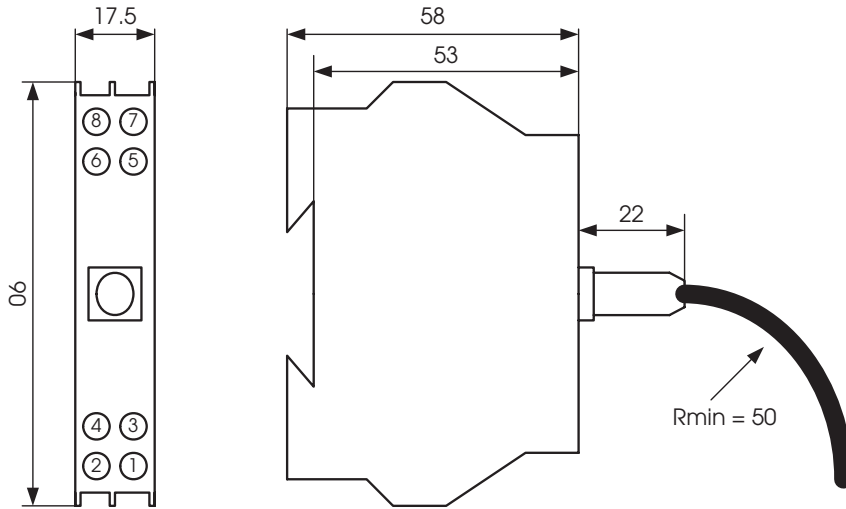

Pin connections OPTV

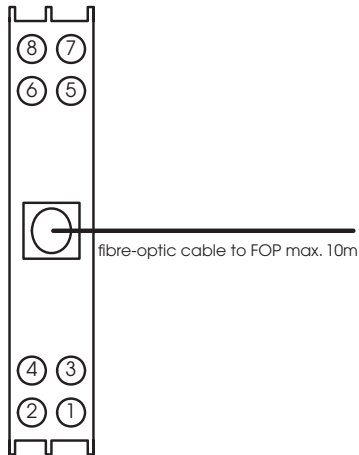

- 1 = signal/out+
- 2 = 0V
- 3 = n.c.
- 4 = UB+
- 5 = detection of line breakage
- 6 = detection of line breakage
- 7 = 2-wire active
- 8 = 2-wire active

connection via screw terminals



- Umax. = 30V
- I_{max.} = 185mA
- C_i = 30nF
- L_i = 265µH

Marking



 Küppers Elektromechanik GmbH
 0123 II 2 G EEx ia IIC T4/T5/T6
 DMT 03 ATEX E 089X

OPTV-02 Ser.Nr. 123456789
 -20°C ≤ Ta ≤ 60°C

U_i = 30 V, I_i = 185 mA
 C_i = 30 nF, L_i = 265 µH

The test sticker indicates year of building and person in charge of test.

Wiring schemes OPTV

3-wire passive

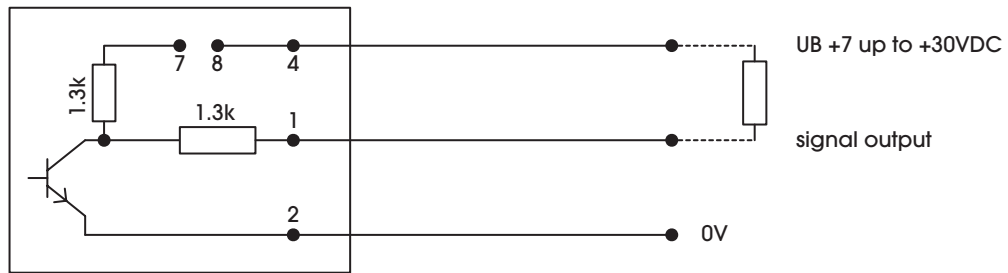

3-wire active

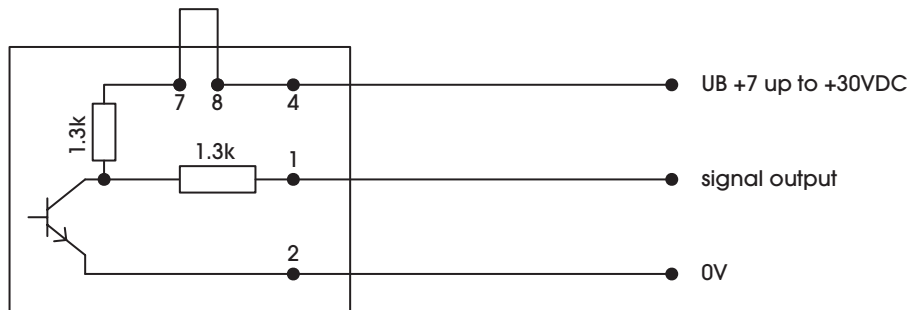

2-wire

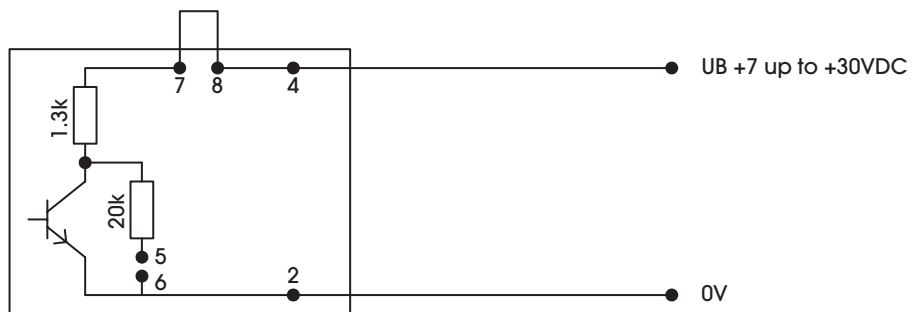

2-wire with KEM separation amplifier type EWS

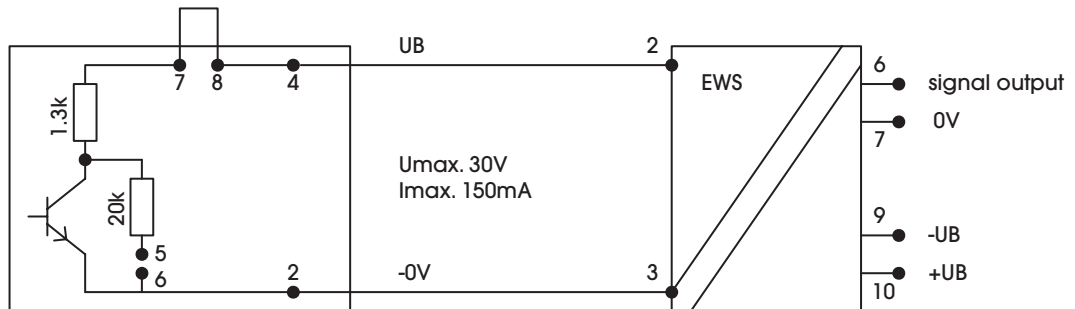

Ordering Information

FOP **/**_*_*_*_*_*_*

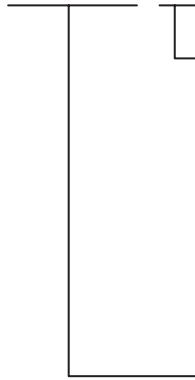

C* = with threadless pickup coil

SK = short pickup coil with thread M 14 x 1.5 for ZHM 02-04

SR = short pickup coil with thread M 14 x 1.5 for ZHM 01/*

SS = long pickup coil with thread M 14 x 1.5 for ZHM 02

60/01/1-CT = with threadless pickup coil for ZHM...CT

** -CM = with threadless pickup coil for LFM 10

Notes on Installation

The following has to be adhered to:

- a) Installation instructions for electrical devices
Installation instructions for associated intrinsically-safe devices
The »Special conditions for safe use« as per EC-Type Examination Certificate
- b) The amplifier has to be installed in a way that the max. ambient temperature does under no circumstances exceed +50°C (consider self heating).
- c) With cables care should be taken, that the max inductivity and capacity of the respective voltage or gas group are not exceeded.
- d) Exceeding or falling below the regular measuring range will cause invalid frequency output signals.
- e) Shielded cables are to be used as connecting lines.
- f) Generally, supplied units have to be connected by an expert according to EMC stipulations.
- g) The light pulse receiver must always be placed inside a housing with protection class IP20.
- h) When the light pulse receiver is installed inside a housing made of plastics or light alloy the material must be in accordance with paragraph 7.3.2 or 8 of EN50014:1997.
- i) The internal wiring in this housing must be in accordance with paragraph 6.4.11 and 7.6.e of EN50020:1994.
- j) Terminals or plug connections for the intrinsically safe current circuits must be arranged as per paragraph 6.3.1 or 6.3.2 of EN50020:1994.
- k) Terminals 5–6 and 7–8 must not be connected with an other device.