



TD and TD*. **-(Ex) Carrier-Frequency Amplifier with Dual Pickup

The integral pickups to detect the r.p.m. of KEM gear flow meters. This happens without contacting the measuring medium.

The output signal of the pickups is amplified and transformed and finally provided as a current or voltage square wave pulse signal for further processing.



The TD* is operated in a three-wire mode. Two output signals phase-shifted by 90° enable for frequency doubling and detection of reverse flow.

Versions TD *.**-(Ex) are IS approved as per EExiaIICT4. It is recommended to use our intrinsically safe power supply type EWS for these versions.

Technical Data

IS approval ATEX 100:
 ambient temperature:
 medium temperature:
 supply voltage:
 quiescent current:
 frequency range:
 phase shift:
 electrical connection:

Ex II 2 G EEx ia IIC T4, BVS01.E.2012
 -20 up to +50°C
 up to +80°C
 8 up to 30 VDC
 < 4 mA each channel
 3 up to 3,000 Hz in accordance with flow meter
 90°, ±30°
 5-pin plug for supply and output signals
 1 = +UB 8 up to 30 V DC
 2 = signal out B: push pull or open collector (f x 1 or f x 2)
 3 = 0 V
 4 = signal out A: push pull or open collector (f x 1 or reverse flow)
 5 = com, common 0 V of both open collector outputs



housing:
 dimensions:
 weight:
 operating modes:

aluminium, IP 65
 l = 50 mm, w = 45 mm, h = 30 mm
 approx. 200 g
 a) 2x single measuring frequency
 (90° phase-shifted)
 output A leads
 b) double measuring frequency and reverse flow detection
 valid only within permissible measuring range
 direction forward = output transistor conducting

output modes:

- push pull
 $I_{out} \text{ max. } 20 \text{ mA}$
- voltage level NPN/OC passive
 $U_{High} > U - (I_{out} \text{ (mA)} \cdot 1.3 \text{ k}\Omega)$
 $U_{Low} < 0.6 \text{ V} + (I_{out} \text{ (mA)} \cdot 1.3 \text{ k}\Omega)$
 $U_{max} = 30 \text{ V}$

jumper layout

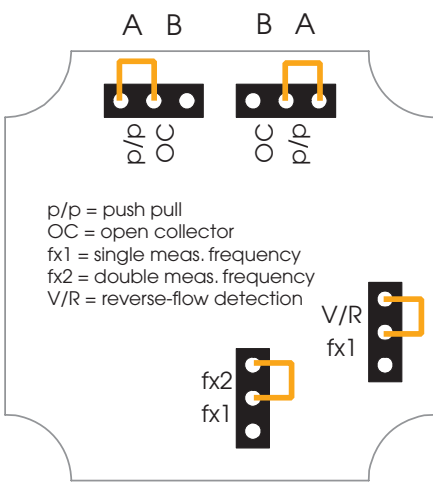

2x push pull

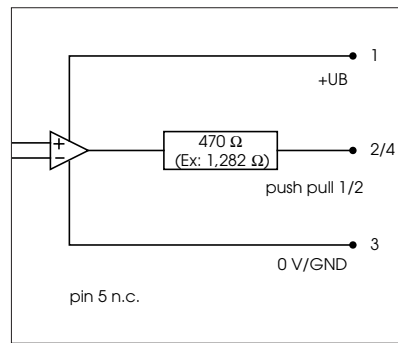

NPN open collector passive

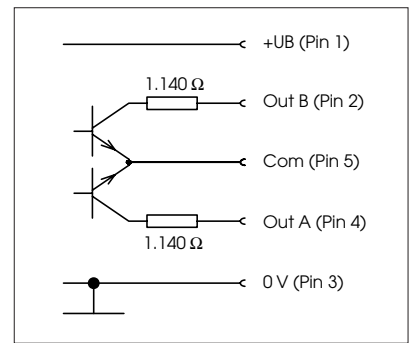

2x push pull output
 1x double measuring frequency
 1x reverse-flow detection

Safety-relevant specifications

Current supply circuit pins 1 and 3

voltage:	$U_i = \text{DC } 30 \text{ V}$
current power:	$I_i = 120 \text{ mA}$
power:	$P_i = 750 \text{ mW}$
effective internal capacity:	$C_i = \text{negligible}$
effective internal inductivity:	$L_i = \text{negligible}$

Current signal circuit pins 2 and 3 push/pull (jumpers VB1 and VB2 in position A)

voltage:	$U_o = \text{DC } 30 \text{ V}$	$U_i = \text{DC } 30 \text{ V}$
current power:	$I_o = 21 \text{ mA}$	$I_i = 120 \text{ mA}$
power:	$P_o = 157 \text{ mW}$	$P_i = 750 \text{ mW}$
internal resistance:	$R_i \geq 1282 \ \Omega$	
effective internal capacity:	$C_i = \text{negligible}$	
effective internal inductivity:	$L_i = \text{negligible}$	

Current signal circuit pins 2 and 3 open collector (jumpers VB1 and VB2 in position B)

voltage:	$U_i = \text{DC } 30 \text{ V}$
current power:	$I_i = 120 \text{ mA}$
power:	$P_i = 750 \text{ mW}$
internal resistance:	$R_i \geq 1140 \ \Omega$
effective internal capacity:	$C_i = \text{negligible}$
effective internal inductivity:	$L_i = \text{negligible}$

The signal current circuit and supply current circuit are galvanically connected

Ordering Information

TD - xx.x - Ex

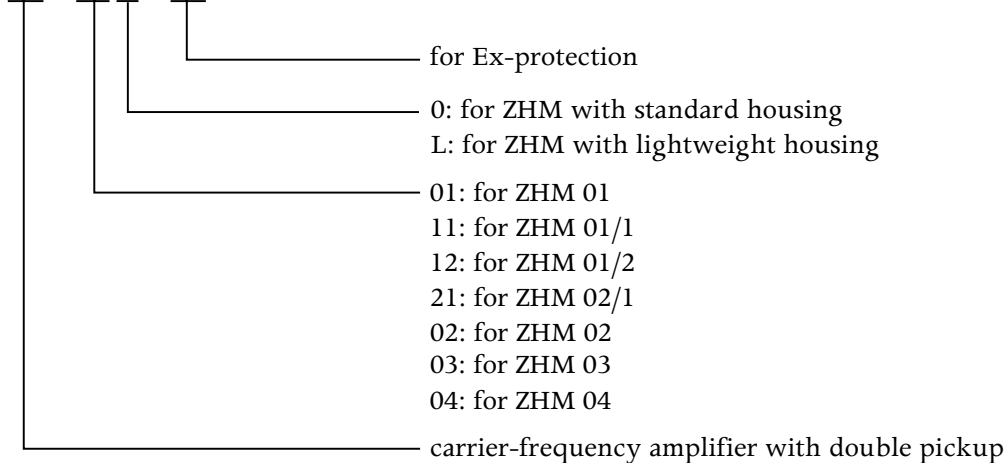

EC Declaration of Conformity

We

KEM Küppers Elektromechanik GmbH
Liebigstraße 2
85757 Karlsfeld,

hereby declare that the carrier-frequency amplifier with dual pickup

TD-**. *-Ex

Equipment group II, category 2G

Ex protection EEx ia II C T4

is in accordance with the following directives:

Type examination for equipment and components intended for use in potentially explosive atmospheres,
directive 94/9/EC

EMC directive EN 50082-2 03.95

EN 50081-2 07.93

EC type examination performed by

Deutsche Montan Technologie

Beylingstraße 65

DE-44329 Dortmund

No. of EC type examination

BVS 01.E.2012

Karlsfeld, 13 June 2001



Signature